

SCREENING BUCKET

<http://tiny.cc/screeningbucket>

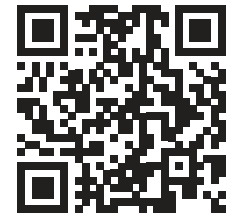

FEATURES & BENEFITS

- Heavy duty construction
- Easy and fast processing
- Separates stone/soil/vegetation
- Screens without crushing or shredding
- Suitable for different types of soil
- Separate project materials on-site, saving time and money

The MultiOne screening bucket separates different sized materials thanks to its unique construction. The purpose of the screening bucket is to separate larger and smaller particles from the soil and not crush the larger material into smaller particles.

The bucket design allows to load and unload the material quickly and easily.

Topsoil making for landscaping, nurseries and wholesale is the principal use while some construction contractors utilise the bucket for screening.

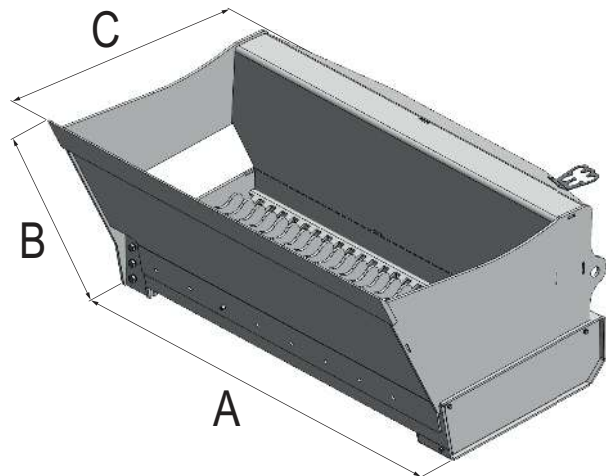

Dimensions (mm/in)		
A	B	C
1176 / 46.3	619 / 24.4	1023 / 40.3

Model	Max Load*	Width (A)	Screened materials (LxHxW)	Weight	Code
Screening bucket	280 kg (617 lbs)	120 cm (47.2 in)	20 - 20 - 35 mm (0.8 - 0.8 - 1.4 in)	320 kg (705 lbs)	C890030

(* verify the lifting capacity of the machine)

Compatibility	1.1	2.3	4.2	5.2	5.3 7.2	6.3	7.3	8.4	8.5 9.5	9.6	10.8 10.9	6.3SD	7.3SD 8.4SD	9.5SD	12.4*	EZ
	Red	Red	Yellow	Green	Green	Green	Green	Green	Green	Green	Green	Green	Green	Green	Green	Yellow

(* C890025 adapter required)

